

P630 High Flow Gas Regulator



- Stainless Steel Internals are Standard
- Steel Units comply with NACE MR0175
- Durable Powder Coated Exterior
- Wide Range of Flow Capacities

The P630 is a spring loaded, direct-operated regulator for high pressure, and high flow applications. The heavy duty construction, made possible by the addition of stainless steel internal components and a powder-coated epoxy exterior finish, makes it ideally suited for the oil and gas industries. All P630 steel units meet NACE MR0175 material requirements for corrosive (sour gas) environments.



Materials of Construction

Body, Bonnet	Cast Iron Steel (1030 WCB)
Diaphragm	Neoprene Fluorocarbon
Seat	Nylon TFE
Orifice	316 Stainless Steel

Applications

- First Cut or Second Stage Regulator
- Farm Taps
- Transmission to Distribution Bridge
- High Pressure Process
- Fuel Gas

P630 Part Matrix

P630	0								
▲	08	▲	▲	▲	▲	▲	▲	▲	Body Size
	16								1"
									2"
									Spring Range
									PSIG BAR
	010								3 - 10 0.2 - .7
	020								8 - 20 0.6 - 1.4
	030								17 - 30 1.2 - 2.1
	040								27 - 40 1.9 - 2.8
	050								27 - 50 1.9 - 3.5
	095								46 - 95 3.2-6.6
	150								90 - 150 6.2-10.3
	200								150 - 200 10.3-13.8
	275								200 - 275 13.8-18.9
	500								275 - 500 18.9-34.5
									Standard NPT Units
									Flanged Connections
	A								150 # RF"
	B								300 # RF"
	C								600 # RF"
									Orifice
	2								1/8"
	3								3/16"
	4								1/4"
	6								3/8"
	8								1/2"
									Seat Material
	1								Nylon
	2								CTFE
									Diaphragm
	2								Fluorocarbon
	3								Neoprene
									Casing Material
	0								Iron
	1								Steel (standard NACE)

Specifications

Maximum Inlet	1500 PSIG	
Outlet	3-500 PSIG	
Body Sizes	1 NPT	
	2 NPT	
Orifice Sizes	1/8"	
	3/16"	
	1/4"	
	3/8"	
	1/2"	
Outlet Ranges		Flow Range*
Low Pressure	3-10 PSIG	200 - 79,000
	8 - 20 PSIG	500 - 82,000
	17 - 30 PSIG	600 - 85,000
	27 - 40 PSIG	800 - 85,000
Regular	27 - 50 PSIG	800 - 85,000
	46 - 95 PSIG	900 - 92,000
	90 - 150 PSIG	2,000 - 88,000
	150 - 200 PSIG	3,400 - 90,000
	200 - 275 PSIG	4,200 - 112,000
	275-500 PSIG	6,600 - 141,000
	* (SCFH of 0.6 S.G. Natural Gas)	
Temp. Range	-20° to 150°F	-29° to 66°C
Weight Approximate		
1"	20 lbs	9 kg
2"	25 lbs	11.25 kg

Wide Open Flow Coefficient for Relief Valve Sizing

Orifice Size (Inches)	C _v
1/8"	0.48
3/16"	1.11
1/4"	2.04
3/8"	4.60
1/2"	8.20

The P630 comes standard with durable stainless steel components for added corrosion protection and long life. All P630 steel units are manufactured to NACE MR0175 standards.

P630 Dimensions

	Body Size		A	B	C	D	E	F
High Pressure P630	1"	mm	193	392	198	29	1"	119
		inches	7.61	15.45	7.79	1.15	NPT	4.67
	2"	mm	207	398	215	45	2"	119
		inches	8.13	15.68	8.45	1.90	NPT	4.67
Low Pressure P630	1"	mm	193	392	231	29	1"	184
		inches	7.61	15.45	9.09	1.15	NPT	7.25
	2"	mm	207	398	398	45	2"	184
		inches	8.13	15.68	9.75	1.90	NPT	7.25

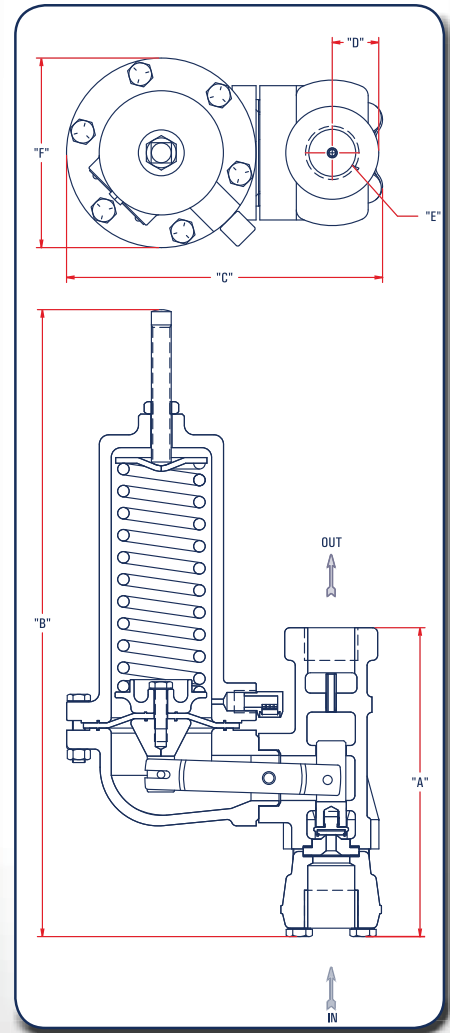

P630 Regulator Rebuild Kits

	Kit Includes	Part Number
P630 High Pressure, Ranges 27 - 50 PSIG and above	Neoprene diaphragms, Nylon valve disk, O-rings, back-up rings, and retaining pin	971-630-000
	Neoprene diaphragm, CTFE valve disk, one body gasket, and 2 orifice gaskets	971-630-100
	Fluorocarbon diaphragms (2), Nylon valve disk, one body gasket, and 2 orifice gaskets	971-630-200
	Fluorocarbon diaphragms (2), CTFE valve disk, one body gasket, and 2 orifice gaskets	971-630-300
P630 Low Pressure, Ranges 3 - 10 PSIG Thru 27 - 40 PSIG	Neoprene diaphragm, Nylon valve disk, one body gasket, and 2 orifice gaskets	971-630-400
	Neoprene diaphragm, CTFE valve disk, one body gasket, and 2 orifice gaskets	971-630-500
	Fluorocarbon diaphragms (2), Nylon valve disk, one body gasket, and 2 orifice gaskets	971-630-600
	Fluorocarbon diaphragms (2), CTFE valve disk, one body gasket, and 2 orifice gaskets	971-630-700

P630 Flow Capacities in SCFH of 0.6 S.G. Natural Gas at 20% Droop

Outlet Pressure Range	Outlet Pressure Setting		Inlet Pressure	1" Body Size					2" Body Size					
				Port Diameter, inches					Port Diameter, inches					
	PSIG	BAR	PSIG	BAR	1/8	3/16	1/4	3/8	1/2	1/8	3/16	1/4	3/8	1/2
3 to 10 PSIG (0.21 to 0.69 BAR)	5	0.34	10	0.69	200	510	990	1700	2200	290	830	1300	3300	5900
			20	1.4	400	770	1200	2000	2700	500	1200	2100	4800	9100
			30	2.1	600	1100	1500	2200	3300	760	1600	2700	7000	11,000
			50	3.5	950	1500	2100	2800	4200	1100	2200	3900	9800	17,000
			60	4.1	1100	1750	2400	3000	4100	1250	2700	4500	11,100	19,500
			75	5.2	1300	2100	2700	3400	4400	1500	3300	5400	13,000	23,000
			100	6.9	1700	2400	2900	4000	4900	1900	4300	7000	17,000	30,000
			150	10.3	2200	3000	3500	4600	5800	2800	6200	10,000	25,000	43,000
			200	13.8	3000	3400	4200	5100	6100	3700	8200	13,000	32,000	57,000
			250	17.2	3500	3800	4300	5900	6800	4500	10,200	17,000	38,000	70,000
	400	27.5	3700	3900	4500	6400	7400	7200	16,000	28,000	64,000			
	500	34.5	4100	4300	4700	7400		9100	19,000	35,000	79,000			
	600	41.4	4300	4600	5000			10,000	24,000	42,000				
	1000	69	4600	4900	5600			18,000	39,000	69,000				
	1500	103	5000	5400				22,000	60,000					
	10	0.69	20	1.4	500	1200	1800	4200	4900	560	1300	2200	5100	9000
			30	2.1	700	1400	2800	4100	5300	770	1500	3000	7000	11,000
			50	3.5	1000	2300	4100	5100	6200	1100	2400	4300	9800	17,000
			60	4.1	1150	2700	4200	5500	6500	1250	2800	5000	11,100	19,500
			75	5.2	1400	3200	4400	6000	6800	1500	3400	5900	13,000	23,000
100			6.9	1600	3800	5000	6400	7300	1900	4400	7600	17,000	30,000	
150			10.3	2400	4800	6200	7300	7900	2800	6200	11,000	25,000	43,000	
200			13.8	3300	5800	6900	7700	8200	3700	8100	14,000	33,000	57,000	
250			17.2	4000	5900	7300	8600	8700	4400	10,000	17,000	41,000	70,000	
400			27.6	5400	6900	7600	9000		7200	16,000	28,000	62,000		
500	34.5	6000	7100	7900	9700		8900	19,000	35,000	76,000				
600	41.4	6500	7300	8200			10,000	23,000	42,000					
1000	69	7200	7700	8400			18,000	40,000	72,000					
1500	103	7400	8400				27,000	60,000						

P630 Flow Capacities in SCFH of 0.6 S.G. Natural Gas at 20% Droop



Outlet Pressure Range	Outlet Pressure Setting		Inlet Pressure		1" Body Size					2" Body Size					
	PSIG	BAR	PSIG	BAR	Port Diameter, inches					Port Diameter, inches					
					1/8	3/16	1/4	3/8	1/2	1/8	3/16	1/4	3/8	1/2	
8 to 20 PSIG (0.55 to 1.4 BAR)	10	0.69	20	1.4	500	700	1400	2200	3600	550	1200	1700	2500	4900	
			30	2.1	700	1300	2100	3100	4300	760	1500	2500	4600	8800	
			50	3.5	900	1900	3200	4300	5400	1000	2300	3800	7800	16,000	
			60	4.1	1050	2300	3500	4700	5800	1200	2700	4500	9900	18,500	
			75	5.2	1300	2800	4000	5200	6400	1500	3300	5600	13,000	23,000	
			100	6.9	1600	3500	4600	5700	6900	1900	4300	7400	17,000	30,000	
			150	10.3	2400	4400	5700	6800	7800	2800	6100	11,000	25,000	44,000	
			200	13.8	3300	4800	6200	7500	8200	3600	8000	14,000	32,000	57,000	
			250	17.2	4000	5800	7000	8000	8700	4400	9500	17,000	37,000	70,000	
			400	27.6	5400	6500	7600	8900		7200	15,000	28,000	60,000		
			500	34.5	6000	6900	7900	9400		8800	19,000	35,000	74,000		
			600	41.4	6500	7000	8200			10,000	23,000	42,000			
	1000	69	7200	7700	8400			18,000	39,000	72,000					
	1500	103	7400	8100				27,000	60,000						
	15	1.0	20	1.4	470	1000	1700	3300	4900	520	1100	1800	3500	5700	
			30	2.1	600	1500	2500	4600	5200	740	1600	2800	5900	10,000	
			50	3.5	1000	2300	3800	5500	5700	1100	2400	4300	9800	16,000	
			60	4.1	1150	2700	4300	6100	6800	1250	2800	5000	11,100	18,500	
			75	5.2	1400	3300	5100	7000	8500	1500	3400	6000	13,000	23,000	
			100	6.9	1900	4300	6200	7600	9600	1900	4400	7800	17,000	30,000	
			150	10.3	2700	6100	7400	8000	9900	2800	6400	11,000	25,000	43,000	
			200	13.8	3600	7500	8500	9600	10,000	3700	8300	14,000	31,000	57,000	
			250	17.2	4700	8400	9100	10,000	11,000	4800	10,000	19,000	39,000	74,000	
			400	27.6	7100	8700	10,000	11,000		7200	16,000	29,000	64,000		
			500	34.5	8300	8800	10,500	12,000		9200	20,000	37,000	82,000		
			600	41.4	8600	9600	10,800			11,000	23,000	42,000			
	1000	69	9600	10,000	11,000			18,000	40,000	71,000					
	1500	103	10,000	11,000				27,000	60,000						
	20	1.4	30	2.4	600	1500	2500	4600	6800	700	1600	2600	5200	9200	
			40	2.8	800	2000	3400	5700	8100	900	2100	3500	7500	12,000	
			50	3.5	1000	2300	4200	6800	9000	1100	2400	4300	9400	15,000	
			60	4.1	1150	2700	4900	7500	9800	1250	2800	5100	11,000	18,000	
			75	5.2	1400	3300	5900	8500	10,000	1500	3400	6100	13,000	23,000	
			100	6.9	1800	4100	7400	9500	11,000	1900	4300	7800	17,000	29,000	
			150	10.3	2700	6100	9200	11,000	12,000	2800	6300	11,000	23,000	42,000	
			200	13.8	3600	8000	10,000	12,000	13,000	3700	8200	14,000	32,000	59,000	
			270	18.6	4500	9800	11,000	13,000	14,000	4900	10,000	19,000	39,000	75,000	
			400	27.6	7200	10,000	13,000	14,000		7300	16,000	28,000	63,000		
			520	35.0	8800	11,000	13,500	15,000		9500	20,000	37,000	82,000		
			600	41.4	10,000	12,000	13,800			11,000	24,000	43,000			
	1020	70.3	11,000	12,300	15,000			18,000	40,000	73,000					
	1500	103	12,000	13,000				27,000	60,000						
	17 to 30 PSIG (1.17 to 2.1 BAR)	20	1.4	30	2.4	590	900	1700	3300	4700	680	1300	2100	3500	6000
				40	2.8	790	1700	2400	4000	6100	890	1800	2800	5100	8200
				50	3.5	900	2200	3600	4900	6900	1000	2300	3700	6200	10,000
60				4.1	1050	2500	4000	5500	7400	1200	2700	4300	7400	12,500	
75				5.2	1300	3000	4500	6400	8100	1500	3300	5300	9200	16,000	
100				6.9	1700	4000	5500	7600	9700	1900	4200	6900	12,000	24,000	
150				10.3	2100	5500	7000	9600	11,000	2200	6100	10,000	21,000	40,000	
200				13.8	3400	6400	9100	11,000	12,000	3500	8000	13,000	32,000	56,000	
270				18.6	4400	8400	10,000	12,000	13,000	4800	10,000	19,000	39,000	75,000	
400				27.6	7000	8700	11,000	13,000		7100	15,000	28,000	63,000		
520				35.9	8200	10,000	12,000	13,800		9300	20,000	37,000	82,000		
600				41.4	9600	11,000	13,000			10,000	24,000	42,000			
1020		70.3	10,000	12,000	14,000			18,000	40,000	72,000					
1500		103	12,000	13,000				27,000	60,000						
30		2.1	40	2.8	820	1700	2700	5100	7600	860	1800	2900	5300	8500	
			50	3.5	900	2200	3600	6400	6700	1000	2300	3800	7300	11,000	
			60	4.1	1100	2600	4400	7500	9800	1200	2700	4700	8900	14,000	
			75	5.2	1400	3300	5400	8800	11,000	1500	3400	5800	11,000	18,000	
			100	6.9	1700	4100	6800	10,000	12,000	1800	4200	7800	16,000	28,000	
			150	10.3	2600	6000	9100	13,000	14,000	2700	6100	11,000	20,000	44,000	
			200	13.8	3500	8000	11,000	14,000	16,000	3600	8100	14,000	24,000	58,000	
			280	19.3	4900	10,500	13,000	15,000	17,000	5000	11,000	20,000	46,000	80,000	
			400	27.6	6900	13,000	15,000	17,000		7000	16,000	28,000	64,000		
			530	36.5	9400	14,500	15,800	19,000		9500	20,000	37,000	86,000		
	600		41.4	9700	15,000	16,000			10,000	23,000	42,000				
	1030		71.0	16,000	18,000	18,000			19,000	41,000	73,000				
1500	103	16,400	18,500				27,000	61,000							

P630 Flow Capacities in SCFH of 0.6 S.G. Natural Gas at 20% Droop

Outlet Pressure Range	Outlet Pressure Setting		Inlet Pressure		1" Body Size					2" Body Size						
					Port Diameter, inches					Port Diameter, inches						
	PSIG	BAR	PSIG	BAR	1/8	3/16	1/4	3/8	1/2	1/8	3/16	1/4	3/8	1/2		
27 to 40 PSIG (1.86 to 2.8 BAR)	30	2.1	40	2.8	800	1500	2400	4400	6400	850	1600	2600	4500	7200		
			50	3.5	900	2000	3200	5600	7700	1000	2200	3500	5900	9700		
			60	4.1	1100	2500	3900	6300	8900	1200	2600	4200	7300	12,000		
			75	5.2	1400	3000	4700	7700	10,000	1500	3200	5300	9400	15,000		
			100	6.9	1700	3900	6400	9400	11,000	1800	4200	6900	12,000	23,000		
			150	10.3	2600	5700	8800	12,000	14,000	2700	6100	10,000	20,000	39,000		
			200	13.8	3500	7000	9400	14,000	15,000	3600	8100	13,000	24,000	57,000		
			280	19.3	4900	10,000	13,000	15,000	16,000	5000	11,000	19,000	45,000	78,000		
			400	27.6	6900	12,000	15,000	17,000		7000	15,000	28,000	64,000			
			530	36.5	9400	12,600	15,800	18,000		9500	20,000	37,000	85,000			
			600	41.4	9700	13,400	16,000			10,000	23,000	42,000				
			1030	71.0	16,000	16,000	18,000			19,000	41,000	73,000				
			1500	103	16,400	18,000				27,000	61,000					
			40	2.8	50	3.5	950	1800	3200	5500	8900	1000	2100	3400	5900	9900
	60	4.1	1100		2300	4100	7600	10,000	1200	2600	4300	7900	12,000			
	75	5.2	1400		3000	5300	9300	12,000	1500	3400	5600	10,000	16,000			
	100	6.9	1800		4100	7000	11,000	14,000	1900	4300	7200	13,000	24,000			
	150	10.3	2700		6000	9500	14,000	17,000	2800	6200	10,000	22,000	39,000			
	200	13.8	3500		7800	12,000	17,000	19,000	3600	8200	14,000	30,000	56,000			
	290	20.0	5100		10,000	15,000	19,000	21,000	5200	11,000	20,000	46,000	81,000			
	400	27.6	7100		15,000	18,000	21,000		7200	16,000	28,000	63,000				
	540	37.2	9500		17,000	19,000	22,000		9600	21,000	38,000	86,000				
	600	41.4	9800		18,000	21,000			10,000	23,000	42,000					
	1040	71.7	17,500		20,000	23,000			18,000	41,000	73,000					
	1500	103	20,000		22,000				27,000	61,000						
	27 to 50 PSIG (1.86 to 3.4 BAR)	50	3.4		60	4.1	900	2000	3100	5200	8100	1000	2100	3200	5300	12,000
					75	5.2	1300	2800	3800	7200	10,000	1400	2900	3900	7300	16,000
				100	6.9	1700	3500	5700	10,500	13,000	1800	3600	5800	10,000	21,000	
150				10.3	2600	5700	8700	13,000	17,000	2700	5800	9000	15,000	36,000		
200				13.8	3500	7800	11,000	16,000	19,000	3600	7900	12,000	21,000	55,000		
300				20.7	5300	10,500	14,000	20,000	23,000	5500	11,000	19,000	48,000	83,000		
400				27.6	6900	13,000	17,000	23,000		7000	15,000	27,000	63,000			
550				19.3	9600	16,000	20,000	26,000		9700	21,000	38,000	88,000			
600				41.4	9800	17,000	21,000			10,000	23,000	42,000				
1050				72.4	17,000	23,000	27,000			19,000	42,000	74,000				
1500				103	19,000	25,000				27,000	60,000					
46 to 95 PSIG (3.2 to 6.5 BAR)				50	3.4	60	4.1	800	1500	2400	4300	6400	900	1600	2500	4400
	75	5.2	1200			2100	3100	5500	8000	1300	2200	3200	6100	9300		
	100	6.9	1500			3100	4200	7500	10,000	1600	3400	4300	7600	12,000		
	150	10.3	2400			4500	6700	11,000	14,000	2500	4600	7100	12,000	19,000		
	200	13.8	3400			6600	9400	14,000	17,000	3500	6700	9600	16,000	27,000		
	300	20.7	5200			8900	11,000	16,000	20,000	5300	10,000	14,000	27,000	51,000		
	400	27.6	6800			11,000	15,000	20,000		6900	13,000	21,000	46,000			
	550	19.3	9500			13,000	17,000	23,000		9600	18,000	29,000	87,000			
	600	41.4	9800			14,000	19,000			10,000	20,000	35,000				
	1050	72.4	14,000			19,000	22,000			18,000	41,000	73,000				
	1500	103	18,000	24,000				26,000	59,000							
	75	5.2	100	6.9	1700	3200	5000	8000	13,000	1800	3300	5200	9000	14,000		
	125		8.6	2200	4300	6700	10,000	15,000	2300	4400	6900	11,000	18,000			
	200		5.2	3500	7300	10,000	16,000	22,000	3600	7400	11,000	19,000	30,000			
	250		17.2	4400	9400	13,000	19,000	24,000	4500	9500	14,000	26,000	44,000			
	325		22.4	5700	11,000	16,000	23,000	27,000	5800	12,000	18,000	36,000	67,000			
	400		27.6	7100	14,000	19,000	27,000		7200	15,000	24,000	47,000				
	575		39.6	9700	18,000	23,000	30,000		9800	22,000	37,000	92,000				
	600		41.4	9900	19,000	25,000			10,000	23,000	39,000					
	1075		74.1	18,000	27,000	32,000			19,000	42,000	75,000					
1500	103		23,000	32,000				24,000	60,000							
90 to 150 PSIG (6.2 to 10.3 BAR)	100	6.9	125	8.6	2000	3600	5500	9200	13,000	2100	3700	5600	9800	15,000		
			150	10.3	2500	4600	6800	11,000	16,000	2600	4900	7400	12,000	18,000		
			200	5.2	3600	6600	9400	13,000	22,000	3700	6900	10,000	17,000	27,000		
			250	17.2	4400	8500	11,000	18,000	26,000	4500	8700	13,000	22,000	34,000		
			300	20.7	5300	9800	14,000	21,000	30,000	5400	10,000	16,000	27,000	44,000		
			350	24.1	6100	10,000	16,000	25,000	32,000	6300	12,000	19,000	33,000	57,000		
			400	27.6	7000	13,000	18,000	27,000		7200	14,000	21,000	39,000			
			600	41.4	9500	18,000	23,000	35,000		10,000	21,000	34,000	69,000			
			1100	75.8	19,500	28,000	35,000			19,000	43,000	74,000				
			1500	103	25,000	35,000				27,000	59,000					
	125	8.6	150	10.3	2400	4600	6700	11,000	17,000	2500	5000	8100	12,000	20,000		
	200		5.2	3500	6800	10,000	15,000	23,000	3600	7400	11,000	19,000	30,000			
	250		17.2	4300	8900	12,000	19,000	29,000	4400	9400	14,000	24,000	39,000			
	300		20.7	5200	10,000	15,000	25,000	34,000	5300	11,000	17,000	31,000	48,000			
	375		25.9	6600	13,000	18,500	28,000	39,000	7000	15,000	24,000	43,000	65,000			
	400		27.6	7300	14,500	19,000	29,000		8300	18,000	28,000	56,000				
	500		34.5	7900	15,000	25,000	36,000		8800	19,000	30,000	59,000				
	625		43.1	10,000	22,000	29,000	41,000		11,000	24,000	40,000	79,000				
	1125		77.6	18,000	33,000	42,000			19,000	44,000	79,000					
	1500		103	26,000	43,000				27,000	60,000						

P630 Flow Capacities in SCFH of 0.6 S.G. Natural Gas at 20% Droop



Outlet Pressure Range	Outlet Pressure Setting		Inlet Pressure		1" Body Size					2" Body Size							
	PSIG	BAR			Port Diameter, inches					Port Diameter, inches							
			PSIG	BAR	1/8	3/16	1/4	3/8	1/2	1/8	3/16	1/4	3/8	1/2			
90 to 150 PSIG (6.2 to 10.3 BAR)	150	10.3	200	13.8	3400	6800	10,000	16,000	26,000	3500	7300	11,000	18,000	30,000			
			250	17.2	4400	8800	13,000	20,000	32,000	4500	9500	15,000	26,000	38,000			
			300	20.7	5300	10,000	15,000	24,000	35,000	5400	11,000	19,000	32,000	52,000			
			400	27.6	7100	14,000	22,000	34,000	42,000	7200	15,000	26,000	46,000	77,000			
			450	31.0	7700	17,000	24,000	36,000		8100	18,000	29,000	54,000				
			650	44.8	9000	24,000	33,000	49,000		10,000	25,000	44,000	88,000				
			800	55.2	13,000	29,000	38,000			14,000	30,000	54,000					
			1150	79.2	20,000	38,000	49,000			21,000	46,000	78,000					
			1500	103	26,000	47,000			27,000	60,000							
150 to 200 PSIG (10.3 to 13.8 BAR)	150	10.3	200	13.8	3400	6200	9300	16,000	24,000	3500	6900	10,000	17,000	28,000			
			250	17.2	4300	8800	12,000	20,000	27,000	4400	9000	13,000	23,000	36,000			
			300	20.7	5300	10,000	15,000	24,000	30,000	5400	11,000	17,000	28,000	47,000			
			400	27.6	7100	14,000	21,000	32,000	38,000	7200	15,000	24,000	40,000	66,000			
			450	31.0	7600	15,000	24,000	36,000		8000	17,000	27,000	46,000				
			650	44.8	9000	21,000	33,000	48,000		10,000	22,000	40,000	74,000				
			800	55.2	13,000	27,000	37,000			14,000	30,000	51,000					
			1150	79.3	19,500	34,000	49,000			20,000	45,000	78,000					
				1500	103	26,000	44,000			27,000	60,000						
		200	13.8	250	17.2	4200	8300	12,000	20,000	30,000	4300	9100	13,000	23,000	42,000		
	300			20.7	5200	10,000	16,000	25,000	35,000	5300	11,000	18,000	33,000	52,000			
	450			31.0	7800	16,000	26,000	43,000	50,000	7900	17,000	29,000	52,000	84,000			
	600			41.1	9500	22,000	34,000	55,000		10,000	23,000	40,000	75,000				
	700			48.3	11,000	25,000	40,000	61,000		12,000	27,000	47,000	90,000				
	800			55.2	13,000	30,000	43,000			14,000	31,000	54,000					
	1000			68.9	16,000	37,000	50,000			17,000	39,000	69,000					
1200	82.7			20,000	41,000	59,000			21,000	48,000	83,000						
			1500	103	26,000	53,000			27,000	60,000							
200 to 275 PSIG (13.8 to 19 BAR)	200	13.8	250	17.2	4200	8200	11,000	20,000	29,000	4300	8900	12,000	23,000	35,000			
			300	20.7	5200	10,000	14,500	25,000	35,000	5300	11,000	18,000	31,000	46,000			
			450	31.0	7700	16,000	24,000	40,000	50,000	7800	17,000	28,000	50,000	78,000			
			600	41.4	9500	22,000	31,000	51,000		10,000	23,000	38,000	70,000				
			700	48.3	11,000	25,000	35,000	55,000		12,000	27,000	45,000	83,000				
			800	55.2	13,000	29,000	42,000			14,000	31,000	52,000					
			1000	68.9	16,000	63,000	50,000			17,000	39,000	68,000					
			1200	82.7	19,000	41,000	55,000			20,000	46,000	83,000					
						1500	103	26,000	51,000			27,000	60,000				
				250	17.2	300	20.7	4900	9000	15,000	28,000	42,000	5000	10,000	17,000	30,000	52,000
			400			27.6	7000	14,000	23,000	40,000	56,000	7100	15,000	25,000	47,000	76,000	
			500			34.5	8500	18,000	29,000	51,000	65,000	8600	19,000	34,000	62,000	103,000	
	600	41.4	9500			22,000	34,000	59,000		10,000	23,000	41,000	78,000				
	750	51.7	12,500			28,000	44,000	69,000		13,000	29,000	51,000	106,000				
	1000	68.9	16,000			39,000	58,000			17,000	40,000	68,000					
	1200	82.7	21,000			49,000	69,000			22,000	50,000	87,000					
						1500	103	26,000	59,000			27,000	60,000				
		275	19			300	20.7	4700	9000	15,000	28,000	39,000	4800	10,000	17,000	29,000	43,000
	400					27.6	6900	14,000	25,000	40,000	54,000	7000	15,000	26,000	47,000	73,000	
	525					36.2	8600	18,000	35,000	68,000	94,000	9200	20,000	36,000	69,000	112,000	
	775					53.4	11,000	28,000	51,000	95,000		12,000	30,000	52,000	112,000		
	1000			68.9	16,000	39,000	67,000			17,000	40,000	68,000					
	1275			89.9	21,000	50,000	87,000			22,000	51,000	89,000					
				1500	103	26,000	60,000			26,000	61,000						
275 to 500 PSIG (19 to 34.5 BAR)	275	19	300	20.7	4500	7500	10,000	20,000	31,000	4600	8400	13,000	23,000	37,000			
			400	27.6	6600	12,000	16,000	31,000	43,000	7000	13,000	20,000	32,000	53,000			
			525	36.2	8600	16,000	21,000	39,000	56,000	9300	18,000	27,000	46,000	73,000			
			775	53.4	11,000	24,000	32,000	55,000		13,000	28,000	44,000	73,000				
			1000	68.9	17,000	32,000	43,000			18,000	37,000	57,000					
			1275	87.9	21,000	40,000	53,000			22,000	48,000	77,000					
						1500	103	26,000	46,000			27,000	57,000				
				300	20.7	400	27.6	6600	11,000	16,000	31,000	42,000	7000	13,000	21,000	35,000	54,000
	550	38	9700			18,000	23,000	44,000	63,000	9800	20,000	30,000	52,000	78,000			
	600	41.4	9900			19,000	26,000	48,000		10,000	21,000	34,000	59,000				
	700	48.3	11,000			23,000	30,000	54,000		12,000	26,000	40,000	72,000				
	800	55.2	13,000			26,000	35,000	61,000		14,000	29,000	47,000	81,000				
	900	62.1	15,000			29,000	39,000			16,000	34,000	53,000					
	1300	90	22,000			43,000	58,000			23,000	50,000	80,000					
						1500	103	26,000	49,000			27,000	58,000				
		400	27.6	500	34.5	8300	16,000	24,000	44,000	62,000	8800	17,000	28,000	49,000	77,000		
	600			41.4	10,000	24,000	33,000	61,000	86,000	11,000	25,000	40,000	75,000	112,000			
	800			55.2	13,000	30,000	41,000	76,000		14,000	31,000	51,000	95,000				
	900			62.1	15,000	34,000	49,000	85,000		16,000	36,000	58,000	110,000				
	1000			68.9	17,000	38,000	54,000			18,000	40,000	66,000					
	1200			82.7	20,000	46,000	63,000			21,000	48,000	80,000					
	1400			96.5	24,000	55,000	76,000			25,000	57,000	96,000					
						1500	103	26,000	60,000			27,000	61,000				
		500	34.5	500	34.5	8700	16,000	26,000	50,000	77,000	9000	18,000	30,000	53,000	89,000		
750	51.7			12,000	28,000	40,000	78,000	100,000	13,000	29,000	48,000	90,000	141,000				
900	62.1			15,000	34,000	52,000	92,000		16,000	35,000	60,000	113,000					
1000	68.9			17,000	39,000	60,000	100,000		18,000	40,000	67,000	130,000					
					1500	103	26,000	59,000	72,000		27,000	60,000	82,000				

P630 Parts

Item	Description	Part Number		
1	Nameplate (requires 4 drive screws for mounting)	632-472-000		
2	Drive Screw (4 required)	648-464-000		
3	Adjusting Screw Spring Range	3-10 PSIG	Low Pressure Ranges	648-462-002
		8-20 PSIG	648-462-001	
		17-30 PSIG	648-462-000	
		27-40 PSIG	648-462-000	
		27-50 PSIG	648-462-002	
		46-95 PSIG	High Pressure Ranges	648-462-001
		90-150 PSIG	648-462-000	
		150-200 PSIG	648-462-000	
200-275 PSIG	648-462-000			
275-500 PSIG	648-462-000			
4	Hex Nut	634-000-056		
5	Upper spring guide - Pressure range to 275 PSIG	626-077-000		
	Upper spring guide - Over 275 PSIG	626-078-000		
6	Bonnet - Iron (27-50 PSIG thru 275-500 PSIG ranges)	604-204-000		
	Bonnet - Steel (27-50 PSIG thru 275-500 PSIG ranges)	604-205-000		
	Bonnet - Iron (3-10 PSIG thru 27-40 PSIG ranges)	604-233-000		
	Bonnet - Steel (3-10 PSIG thru 27-40 PSIG ranges)	604-234-000		
7	Range Spring	3-10 & 27-50 PSIG	Low Pressure	655-659-000
		8-20 & 46-95 PSIG		655-659-001
		17-30 & 90-150 PSIG		655-659-002
		27-40 & 150-200 PSIG	High Pressure	655-659-003
		200-275 PSIG		655-659-004
		275-500 PSIG		655-659-005
8	Diaphragm Screw	648-463-000		
9	Lower spring guide - 3-10 PSIG thru 27-40 PSIG	626-095-000		
	Lower spring guide - 27-50 PSIG thru 200-275 PSIG	637-304-000		
	Lower spring guide - 275-500 PSIG	637-305-000		
10	Diaphragm	Neoprene (27-50 PSIG Thru 275-500 PSIG)	618-068-000	
		Fluorocarbon (2 required for 27-50 PSIG thru 275-500 PSIG)	618-068-001	
		Neoprene (3-10 PSIG thru 27-40 PSIG)	618-073-000	
		Fluorocarbon (2 required for 3-10 PSIG thru 27-40 PSIG)	618-073-001	
11	Hex nut for the iron diaphragm housing (4 required for ranges 27-50 PSIG or greater, 10 required for 3-10 PSIG thru 27-40 PSIG)	634-000-112		
12	Build Screws	For the iron diaphragm housing (4 required for 27-50 PSIG thru 275-500 PSIG ranges)	648-463-003	
		For the steel diaphragm housing (4 required for 27-50 PSIG Thru 275-500 PSIG ranges)	648-463-005	
		For the iron diaphragm housing (10 required for 3-10 PSIG Thru 27-40 PSIG ranges)	648-463-003	
		For the steel diaphragm housing (10 required for 3-10 PSIG Thru 27-40 PSIG ranges)	648-463-007	
13	Connector piston assembly	Aluminum trim	827-004-000	
		Stainless Steel trim	827-004-001	
		Aluminum trim, NACE	827-006-000	
		Stainless Steel trim, NACE	827-006-001	
14	Diaphragm Housing	Iron (27-50 PSIG Thru 275-500 PSIG)	629-199-000	
		Steel (27-50 PSIG Thru 275-500 PSIG)	629-200-000	
		Iron (3-10 PSIG Thru 27-40 PSIG)	629-224-000	
		Steel (3-10 PSIG Thru 27-40 PSIG)	629-225-000	
15	Lever Assembly	(27-50 PSIG Thru 275-500 PSIG)	827-003-000	
		NACE (27-50 PSIG Thru 275-500 PSIG)	827-007-000	
16	Pin	All Low Pressure, (3-10 PSIG Thru 27-40 PSIG)	827-010-000	
			635-052-000	
17	Gasket - Composite	624-056-000		

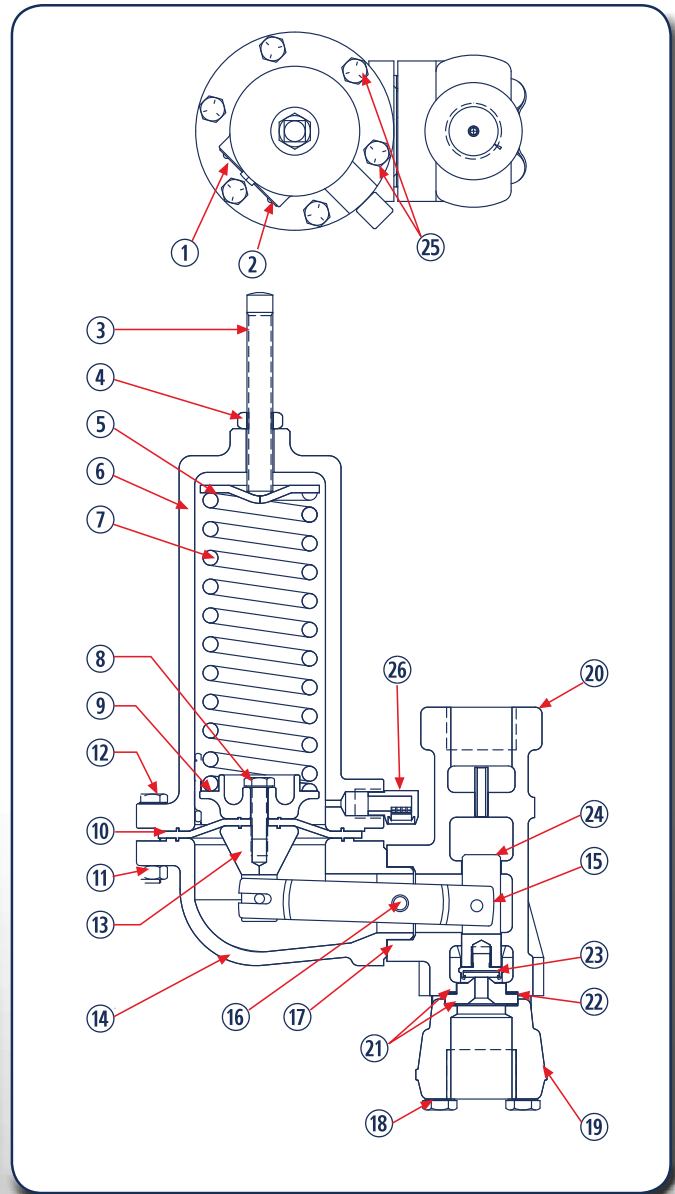

Item	Description	Part Number	
18	Build screw	1" body (4 required)	648-463-004
		2" body (4 required)	648-463-006
19	Inlet adapter	1 NPT 1030 Carbon Steel	679-036-000
		2 NPT 1030 Carbon Steel	679-037-000
20	Body	1 NPT Iron	805-308-001
		1 NPT Steel	805-308-000
		2 NPT Iron	664-277-000
		2 NPT Steel	664-279-000
21	Body Gaskets Composite (2 required)	1/8"	624-058-000
		3/16"	688-010-000
22	Orifice	1/4"	688-010-001
		3/8"	688-010-002
		1/2"	688-010-003
		1/2"	688-010-004
23	Seat Assembly	SS holder/nylon disk	822-018-000
		SS holder/TFE disk	822-018-001
24	Valve Carrier	673-017-000	
25	Build screw for steel diaphragm housing (2 required)	648-463-001	
26	Vent protector assembly	836-004-000	
27	Cap screws (Body to Housing) not shown	648-463-002	
28	NACE Tag (not shown-Steel Units only)	632-503-000	
29	Piston - 3-10 PSIG thru 27-40 PSIG Ranges only	637-315-000	

P630R High Flow Gas Relief Valve



- Stainless Steel Internals are Standard
- Steel Units comply with NACE MR0175
- Durable Powder Coated Exterior
- High Flow Capacities

Applications

- Compressor Stations
- Refineries
- High Pressure Plants

The BelGAS P630R is a spring loaded, adjustable relief valve designed for relief pressure settings from 3 PSIG to 250 PSIG (0.21 to 17.3 BAR). The heavy duty construction, made possible by the addition of stainless steel internal components and a powder-coated epoxy exterior finish, makes it ideally suited for the oil and gas industries. All P630 steel units meet NACE MR0175 material requirements for corrosive (sour gas) environments.

Materials of Construction

Body, Bonnet	Cast Iron
	Steel (1030 WCB)
Diaphragm	Neoprene
	Fluorocarbon
Seat	Nylon
	TFE
Orifice	316 Stainless Steel



P630R Part Matrix

P630R		8	0			
						Body Size
	08					1"
	16					2"
						Spring Range
						PSIG BAR
	008					3 - 8 0.21 - 0.55
	017					6 - 17 0.41 - 1.17
	022					15 - 22 1.02 - 1.52
	035					20 - 35 1.38 - 2.41
	050					35 - 50 2.41 - 3.45
	070					30 - 70 2.1 - 4.8
	095					50 - 95 3.4 - 6.6
	175					75 - 175 5.2 - 12.1
	250					150 - 250 10.3 - 17.2
	0					Standard NPT Units
						Flanged Connections
	A					150 # RF"
	B					300 # RF"
	C					600 # RF"
						Diaphragm
				2		Fluorocarbon
				3		Neoprene
						Casing Material
				0		Cast Iron
				1		Steel

Specifications

Maximum Allowable Relief Inlet	Relief Pressure Setting Plus 250 PSIG	
Outlet	3-250 PSIG	
Body Sizes	1 NPT	
	2 NPT	
Outlet Ranges		
	3 - 8 PSIG	Low Pressure
	6 - 17 PSIG	
	15 - 22 PSIG	
	20 - 35 PSIG	
	35 - 50 PSIG	
	30 - 70 PSIG	High Pressure
	50 - 95 PSIG	
	75 - 175 PSIG	
	150 - 250 PSIG	
Temp. Range	-20° to 150°F	-29° to 66°C
Orifice Size	1/2"	
Weight Approximate		
1"	20 lbs	9 kg
2"	25 lbs	11.25 kg

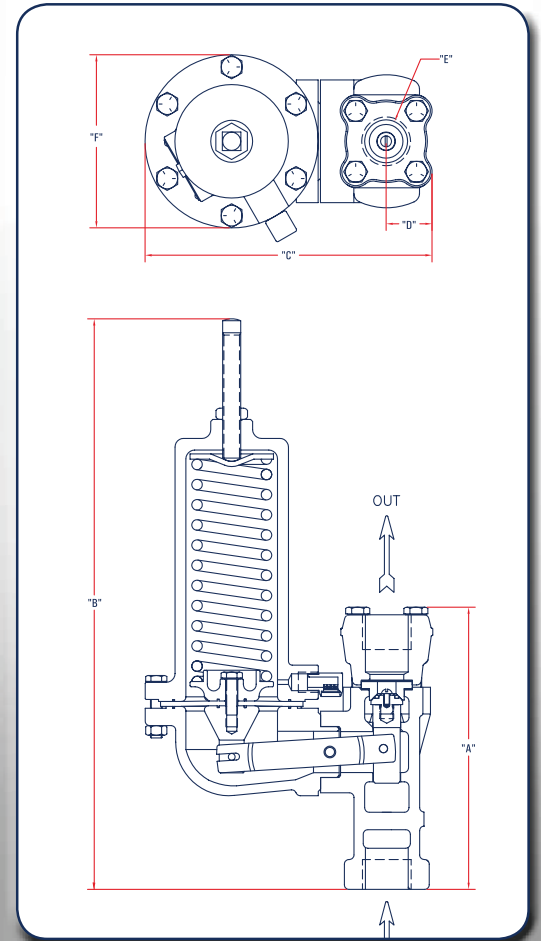

Body Size		A	B	C	D	E	F
1" P630R	mm	193	391	198	29	1"	119
	High Pressure inches	7.61	15.39	7.79	1.15	NPT	4.67
2" P630R	mm	211	398	215	45	2"	119
	High Pressure inches	8.31	15.66	8.45	1.90	NPT	4.67
1" P630R	mm	193	391	231	29	1"	184
	Low Pressure inches	7.61	15.39	9.09	1.15	NPT	7.25
2" P630R	mm	211	398	248	45	2"	184
	Low Pressure inches	8.31	15.66	9.75	1.90	NPT	7.25

P630R Parts

Item	Description	Part Number	
1	Nameplate (requires 4 drive screws for mounting)	632-472-000	
2	Drive Screw (4 required)	648-464-000	
3	Adjusting Screw	Spring Ranges	
		3-8 PSIG	648-462-002
		6-17 PSIG	648-462-001
		15-22 PSIG	648-462-000
		20-35 PSIG	648-462-004
		35-50 PSIG	648-462-004
		30-70 PSIG	648-462-001
		50-95 PSIG	648-462-000
4	Hex Nut	75-175 PSIG	648-462-003
		150-250 PSIG	648-462-003
5	Upper Spring Guide	Pressure Ranges: 3-8, 6-17, 15-22, 20-35, & 30-70, 50-95 & 75-175 PSIG	626-077-000
		Pressure Ranges: 35-50 & 150-250 PSIG	626-078-000
6	Bonnet - Iron (30-70 PSIG thru 150-250 PSIG)	604-204-000	
	Bonnet - Steel (30-70 PSIG thru 150-250 PSIG)	604-205-000	
	Bonnet - Iron (3-8 PSIG thru 35-50 PSIG)	604-233-000	
	Bonnet - Steel (3-8 PSIG thru 35-50 PSIG)	604-234-000	
7	Range Spring	3-8 PSIG	655-659-000
		6-17 PSIG	655-659-001
		15-22 PSIG	655-659-002
		20-35 PSIG	655-659-003
		35-50 PSIG	655-659-004
		30-70 PSIG	655-659-001
		50-95 PSIG	655-659-002
		75-175 PSIG	655-659-003
8	Diaphragm Screw	150-250 PSIG	655-659-004
			648-463-000
9	Lower Spring Guide	3-8 PSIG	626-095-000
		6-17 PSIG	
		15-22 PSIG	
		20-35 PSIG	
		35-50 PSIG	637-304-000
		30-70 PSIG	
		50-95 PSIG	
		75-175 PSIG	
10	Diaphragm	150-250 PSIG	637-305-000
		Pressure Ranges: 3-8, 6-17, 15-22, 20-35, & 35-50 PSIG	
10	Diaphragm	Neoprene	618-073-000
		Fluorocarbon (2 required)	618-073-001
	Diaphragm	Neoprene	618-068-000
		Fluorocarbon (2 required)	618-068-001
11	Hex nut for the iron diaphragm housing	Pressure Ranges: 3-8, 6-17, 15-22, 20-35, & 35-50 PSIG (10 Required)	634-000-112
		Pressure Ranges: 30-70, 50-95, 75-175, & 150-250 PSIG (4 Required)	

Item	Description	Part Number	
12	Build Screws	For the Iron Diaphragm Housing Ranges: 3-8, 6-17, 15-22, 20-35, & 35-50 PSIG (10 Required)	648-463-003
		For the Steel Diaphragm Housing Ranges: 3-8, 6-17, 15-22, 20-35, & 35-50 PSIG (10 Required)	648-463-007
		For the Iron Diaphragm Housing Ranges: 30-70, 50-95, 75-175, & 150-250 PSIG (4 Required)	648-463-003
		For the Steel Diaphragm Housing Ranges: 30-70, 50-95, 75-175, & 150-250 PSIG (4 Required)	648-463-005
13	Connector piston assembly Aluminum trim	827-004-000	
	Connector piston assembly Stainless Steel trim	827-004-001	
	Connector piston assembly Aluminum trim, NACE	827-006-000	
	Connector piston assembly Stainless Steel trim, NACE	827-006-001	
14	Diaphragm Housing	Iron (Ranges: 3-8, 6-17, 15-22, 20-35, & 35-50 PSIG)	629-224-000
		Steel (Ranges: 3-8, 6-17, 15-22, 20-35, & 35-50 PSIG)	629-225-000
		Iron (Ranges: 30-70, 50-95, 75-175, & 150-250 PSIG)	629-199-000
		Steel (Ranges: 30-70, 50-95, 75-175, & 150-250 PSIG)	629-200-000
15	Lever Assembly	(Ranges: 3-8, 6-17, 15-22, 20-35, & 35-50 PSIG)	827-010-000
		(Ranges: 30-70, 50-95, 75-175, & 150-250 PSIG)	827-003-000
		NACE units only (Ranges: 30-70, 50-95, 75-175, & 150-250 PSIG)	827-007-000
16	Pin	635-052-000	
17	Gasket - Composite	624-056-000	
18	Build screw	1" body (4 required)	648-463-004
		2" body (4 required)	648-463-006
19	Inlet adapter	1 NPT 1030 Carbon Steel	679-036-000
		2 NPT 1030 Carbon Steel	679-037-000
20	Body	1 NPT Iron	805-308-001
		1 NPT Steel	805-308-000
		2 NPT Iron	664-277-000
		2 NPT Steel	664-279-000
21	Body Gaskets Composite (2 required)	624-058-000	
22	Orifice 1/2"	650-126-000	
23	Seat Housing, SS	629-214-000	
24	Valve Carrier	673-017-000	
25	Build screw for steel diaphragm housing (2 required)	648-463-001	
26	Vent protector assembly	836-004-000	
27	Cap screws (Body to Housing) not shown	648-463-002	
28	O-ring, Neoprene	649-292-000	
	O-ring, Fluorocarbon	649-300-000	
29	Housing Screw	648-486-000	
30	Housing Plate	638-064-000	

P630R High Flow Gas Relief Valve

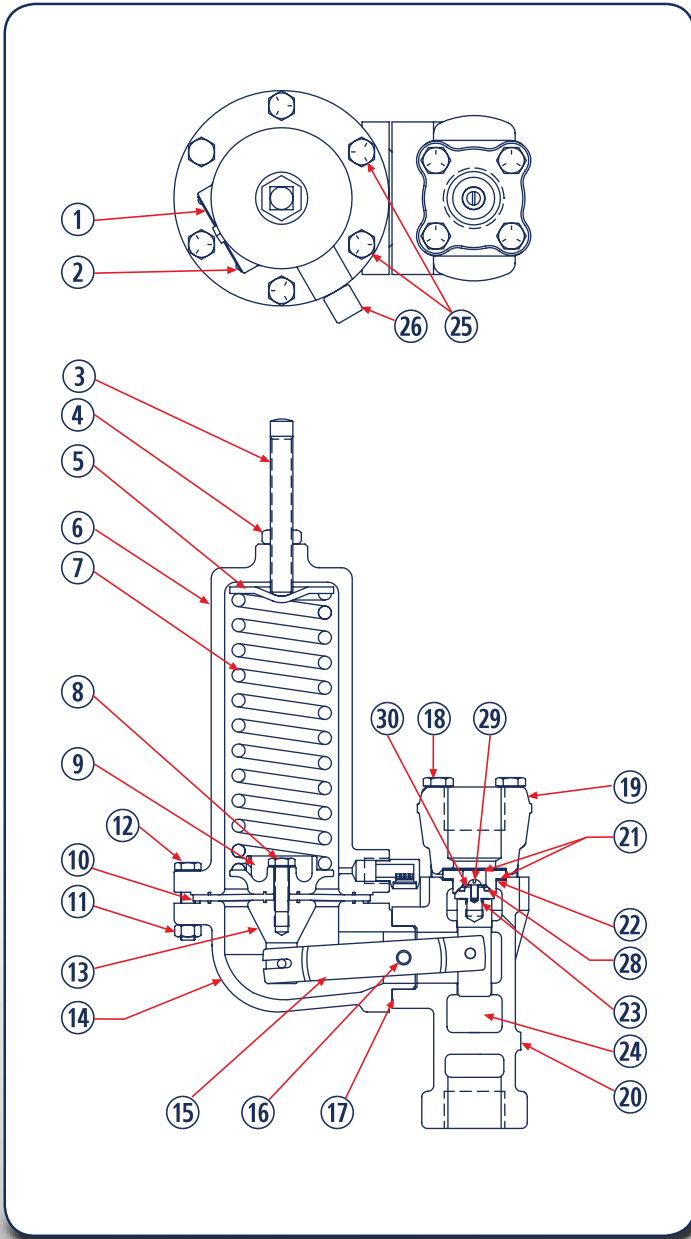

Relief Capacity Table - P630R High Pressure

Initial Relief Pressure Setting		Capacities, SCFH of 0.6 S.G. Natural Gas	
		10% Pressure Increase	20% Pressure Increase
PSIG	BAR	SCFH	SCFH
50	3.4	2900	7100
75	5.2	2700	7480
250	6.9	3260	9670
125	8.6	5500	14,200
175	12.1	5480	19,000
250	17.2	13,500	48,000

Note: Maximum working pressure above setting is 250 PSIG (17.2 BAR)

Relief Capacity Table - P630R Low Pressure

Initial Relief Pressure Setting		Capacities, SCFH of 0.6 S.G. Natural Gas	
		10% Pressure Increase	20% Pressure Increase
PSIG	BAR	SCFH	SCFH
5	0.35	640	2710
10	0.69	1420	2900
15	1.0	2000	4200
20	1.4	2130	4450
35	2.4	3030	7230
50	3.4	4900	14000

Note: Maximum working pressure above setting is 250 PSIG (17.2 BAR)

Spring Range

Spring Range	Adj. Screw (3)	Range Spring (7)	Spring Color Code
3 - 8 PSIG	648-462-002	655-659-000	Red Stripe
6 - 17 PSIG	648-462-001	655-659-001	Olive Drab
15 - 22 PSIG	648-462-000	655-659-002	Silver
20 - 35 PSIG	648-462-004	655-659-003	Green Stripe
35 - 50 PSIG	648-462-004	655-659-004	Blue Stripe
30 - 70 PSIG	648-462-001	655-659-001	Olive Drab
50 - 95 PSIG	648-462-000	655-659-002	Silver
75 - 175 PSIG	648-462-003	655-659-003	Green Stripe
150 - 250 PSIG	648-462-003	655-659-004	Blue Stripe

P630R Relief Valve Rebuild Kits

	Kit Includes	Part Number
Pressure Ranges: 30 - 70 PSIG thru 150-250 PSIG	Neoprene diaphragms, nitrile O-ring, seat housing assembly and 2 orifice disks	971-630-R00
Pressure Ranges: 30 - 70 PSIG thru 150-250 PSIG	Fluorocarbon diaphragms, fluorocarbon O-ring, seat housing assembly and 2 orifice gaskets	971-630-R01
Pressure Ranges: 3 - 8 PSIG thru 35 - 50 PSIG	Low pressure Neoprene diaphragm, nitrile O-ring, seat housing assembly and 2 orifice disks	971-630-R02
Pressure Ranges: 3 - 8 PSIG thru 35 - 50 PSIG	Low pressure fluorocarbon diaphragms, fluorocarbon O-ring, seat housing assembly and 2 orifice disks	971-630-R03
P630R Conversion Kit (Nitrile Diaphragm)	Kit includes: Seat Assembly and Orifice	971-635-000
P630R Conversion Kit (Fluorocarbon Diaphragm)	Kit includes: Seat Assembly and Orifice	971-635-001



Notes:

